

Charge Amps Aura



Installation Manual

English

Table of content

1	Safety	5
2	Technical data	6
3	Product overview	9
3.1	Package contents	10
4	Before installation	12
4.1	Recommended tools	12
4.2	Materials provided by installer	12
4.3	Mounting requirements	13
4.4	Electric requirements	14
4.4.1	Short circuit safety	14
4.4.2	Residual current safety	14
4.5	Internet access	15
4.5.1	Wi-Fi	15
4.5.2	4G-LTE	16
4.5.3	LAN	16
4.5.4	Network daisy chain of Charge Amps Aura	17
5	Installation	18
5.1	Mounting	18
5.2	Connection	22
5.2.1	Cable connection	22
5.3	Reassemble	28

6	Configuration	29
6.1	Create a Charge Amps Partner Account	29
6.2	Connect Charge Amps Aura OCPP 1.6J version	30
6.2.1	Connect via Charge Amps Aura Wi-Fi access point	31
6.2.2	Connect via LAN	32
6.2.3	Connect via 4G-LTE	33
6.2.4	Local management interface settings	34
6.3	Connect Charge Amps Aura CAPI version	35
6.3.1	Connect via Charge Amps Aura Wi-Fi access point	36
6.3.2	Connect via LAN	37
6.3.3	Connect via 4G-LTE	37
7	Cloud connectivity	38
8	Dismounting	39
9	Maintenance	39
9.1	Regular maintenance	39
9.2	Preventative maintenance	40
10	Product support and service	40
11	Warranty	40



Respect the environment! Must not be discarded with household waste! This product contains electrical or electronic components. Leave the product for separate collection and proper treatment at a designated location e.g. the local authority's recycling station.



In conformity with the relevant EU directives.

Neglecting to follow and carry out the directions, instructions and safety precautions in this Installation Manual implies that any warranty provisions will be cancelled and that Charge Amps can reject any and all claims for compensation in connection with any injuries/damage or incidents – direct or indirect – that are a result of such negligence.

Charge Amps AB does not give any warranties as to the accuracy or completeness of this document and shall have no liability for the consequences of using such information. Charge Amps AB reserves the right to make changes to information published in this document without notice. Visit www.chargeamps.com for the latest document releases.

© Copyright Charge Amps AB. All rights reserved. Copying, amending and translating are strictly forbidden without prior written approval from Charge Amps AB.

1 Safety

WARNING! Read all instructions before installation!

- The product must only be installed or opened by a qualified electrician in accordance with the Installation Manual.
- Make sure to switch the power off at the main switch before installation or service.
- For this product, automatic reclosing of protective devices are not allowed.
- Improper use and negligence to follow the instructions of this Installation Manual may create a risk of personal injury.
- National installation requirements and restrictions apply.
- Only use this product for charging compatible electric vehicles.
- Inspect the product for visible damage before use.
- Never attempt to repair or use the product if it is damaged.
- Make sure that the product is in good condition and that all cables are properly seated before use.
- Do not immerse the product in water, subject it to physical abuse or insert foreign objects in any part of the product.
- Never attempt to disassemble the product in any way other than what is described in the Installation Manual.
- Make sure no flammable, explosive, corrosive or combustible materials, chemicals, or fumes are nearby the mounting position.
- Make sure the front cover does not interfere with any cables inside and that the front cover is locked in place upon completion of installation.
- To avoid muscle strain or back injury, use lifting aids and proper lifting techniques.

2 Technical data

Charging mode	Mode 3
EV power supply identifier	
Metering	1 to 3 phase voltage, current and power
Socket	Type 2, up to 2x22 kW
Rated voltage (U_n)	230/400 V
Rated insulation voltage (U_i)	250/400 V
Rated impulse withstand voltage (U_{imp})	4 kV
Rated operational voltage (U_e)	230/400 V
Rated frequency (f_n)	50 Hz
Rated current (I_n)	63 A
Rated output current (I_{nc})	32 A/socket
Rated diversity factor (RDF)	1 (can be lowered if used together with a load balancing functionality)
Rated peak withstand current (I_{pk})	3 kA, 20 kA ² s
Rated short-time withstand current (I_{cw})	192 A for 2 s
Residual current safety	Separate DC fault current protection. Type A RCBO complying with EN 61009-1 and EN 61009-2-1 is integrated to the charging station for each socket.
Protection against electrical shock	Class I
Types of earthing system	TN, TT and IT

Overvoltage category	III
Pollution degree	3
Electromagnetic compatibility	Environment B
Operating temperatures	-35°C to +45°C
Altitude	0 m to 2000 m
IP code	IP55
IK code	IK10
Mechanical resistance	High
Dimensions (W x D x H)	367 x 159 x 405 mm
Weight	10 kg
Characteristics of power supply and output	AC EV supply equipment connected to AC supply network, permanently connected.
External design and method of mounting	Enclosed wall-mounted surface type: - surface mounted on walls - stationary ground and floor mounted installation with accessory Charge Amps Pole mount
Type of construction	Fixed
Intended use and location type	By ordinary persons, indoor and outdoor installation with non-restricted access
RFID	Type: ISO/IEC 14443 Typ A 13.56MHz Mifare Range: 13.553 – 13.567 MHz Output: 31 dBm

Wi-Fi	Type: 802.11 b/g/n Range: 2400 – 2500 MHz Max output: 20/17/14 dBm@802.11 b/g/n
Communication protocol	OCP 1.6J: Valid for Charge Amps Aura with product number 130908 & 130909. CAPI: Valid for Charge Amps Aura with product number 101010 and 101010-LTE.
Cellular networks communication (only applies to Charge Amps Aura with product number 130908 and 101010-LTE).	Type: GSM, GPRS, EDGE, UMTS/HSPA+, LTE Range: 698 – 960 / 1710 – 2690 MHz Max. output: 33 dBm@GSM, 24 dBm@WCDMA, 23 dBm@LTE SIM Card: Standard SIM (25mm x 15mm)

3 Product overview

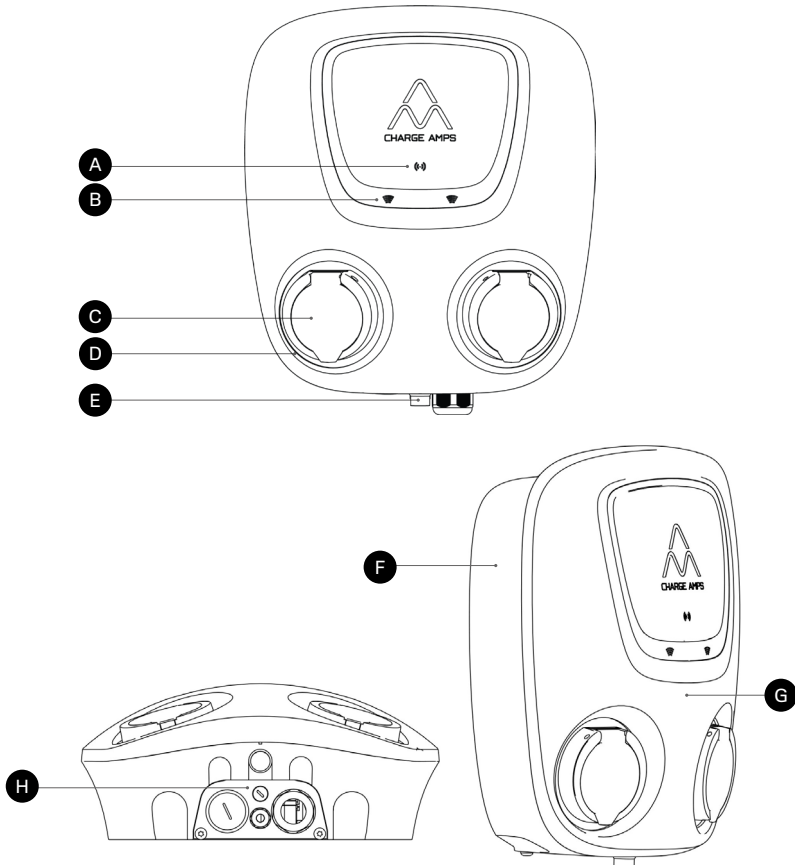

- | | | | |
|----------|--------------|----------|--|
| A | RFID reader | E | Cylinder lock |
| B | RFID light | F | Back cover |
| C | EV socket | G | Front cover |
| D | Socket light | H | Cable slide: data and power cable in/out |

3.1 Package contents

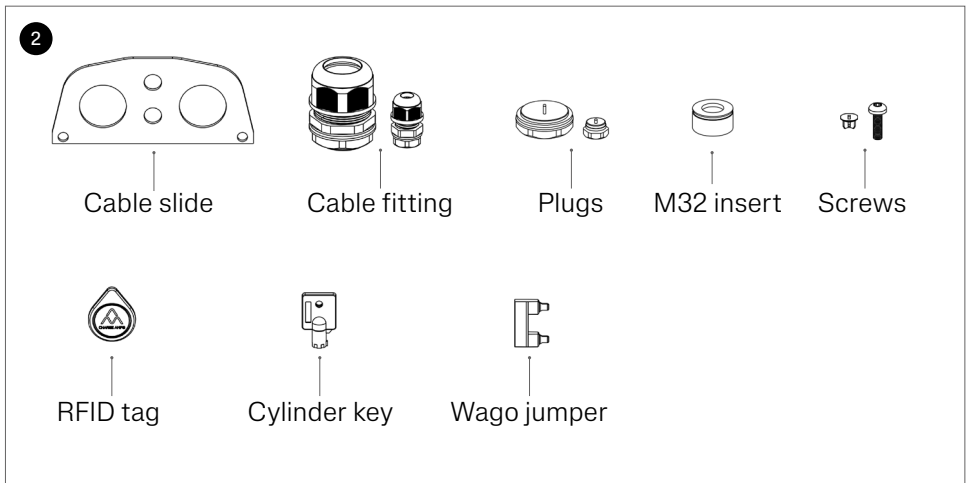
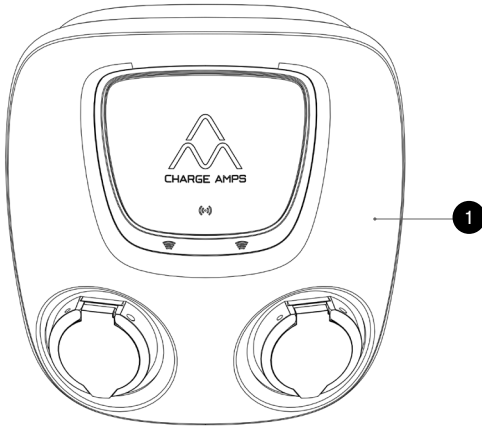

❶ Charge Amps Aura

❷ Accessories:

- Cable slide
- Cable fitting for power (M32): 13 - 17.5 mm and 17 - 25 mm
- Cable fitting for data (M12): 4 - 8 mm
- Plugs for non-used cable entries
- M32 insert only
- Screws
- 2x RFID tags
- 2x Cylinder lock keys
- Wago jumper for IT network connection (MPN: 2016-433)

Additional contents:

- Document with serial number and password
- Quick Guide

4 Before installation

4.1 Recommended tools

- 3.5 mm flat head screwdriver
- Drill
- Multimeter
- Laser/spirit level
- Wire stripper for cabling
- Mobile phone, tablet or computer

4.2 Materials provided by installer

- 4 x M6x30 mm or longer, flat head stainless screws type A2 or A4 with associated washers type A2 or A4 having a maximum outer diameter of 20 mm and plugs (if required, depending on wall conditions)
- Installation cable, according to the charging capability of the selected product
- Ethernet cable

4.3 Mounting requirements

- If possible, do not mount the Charge Amps Aura in direct sunlight.
- Make sure the wall can support a weight of 10 kg and the tractive force from the inserted cabling.
- Do not install Charge Amps Aura in confined spaces.
- Use screws and plugs (if required) suitable for the wall material.
- Charge Amps Aura must be mounted upright.
- Permissible mounting height 900 -1450 mm, measured from the ground to the bottom of Charge Amps Aura.
- For alternative mounting requirements for a pole mount, contact Charge Amps Support.

4.4 Electric requirements

N.B: Local regulations might add additional requirements for the electrical installation and must always be met.

- Charge Amps Aura must be earthed through a permanent electrical installation.
- Only insert the power cable through the specified cable entry. Cables must not be passed through the rear housing.

4.4.1 Short circuit safety

Make sure the installation for Charge Amps Aura is properly fused up to 63 A with one of the following:

- B- or C-curve MCB* with energy limiting class 3.
- D-type fuse category gG.
- NH blade fuse category gG.

*MCB = Miniature Circuit Breaker, B Curve MCBs trip at 3–5 times the rated current and C Curve MCBs trip at 5–10 times the rated current.

4.4.2 Residual current safety

Following is integrated to Charge Amps Aura for each socket:

- Type A RCBO complying with EN 61009-1 and EN 61009-2-1.
- Separate DC fault current protection.

4.5 Internet access

Both Wi-Fi, LAN connection and 4G-LTE (only available for Charge Amps Aura with product number 130908 and 101010-LTE) is available for Charge Amps Aura.

4.5.1 Wi-Fi

Once the power is switched on, Charge Amps Aura will provide a Wi-Fi access point which is available for 10 minutes. You can use the Wi-Fi access point to connect Charge Amps Aura to the Wi-Fi network of the facility.

N.B: The Charge Amps Aura Wi-Fi access point is deactivated if one of the RJ45 ports are connected.

Before installing Charge Amps Aura, make sure the Wi-Fi network of the facility is supported:

Supported networks:

- Wi-Fi 2,4 GHz according to 802.11b/g/n.

Recommendation for network security and encryption:

- WPA using TKIP: supported but not recommended.
- WPA2 using AES: recommended.
- WPA3: not supported.

4.5.2 4G-LTE

N.B: Only applicable to Charge Amps Aura with product number 130908 and 101010-LTE.

N.B: If you wish to use the Charge Amps Aura Wi-Fi access point to configure Charge Amps Aura via the local management interface, make sure to disconnect the 4G-LTE modem from the RJ45 port.

The Charge Amps Aura 4G-LTE model comes with the 4G-LTE modem connected to one of the RJ45 ports on the main card. Once the power is switched on, and a SIM card is inserted, Charge Amps Aura will automatically connect to the 4G-LTE network.

4G-LTE modem model:

- Teltonika TRB 140. If you wish to log in to the 4G-LTE modem on Charge Amps Aura with product number 130908, see the TRB 140 User Manual to find the default password and other information.
- To log in to the 4G-LTE modem on Charge Amps Aura with product number 101010-LTE, please contact Charge Amps Support.

4.5.3 LAN

It is possible to connect Charge Amps Aura via a network cable. A cat5 cable, or better, is required.

4.5.4 Network daisy chain of Charge Amps Aura

N.B: There's a dependency between upstream and downstream chargers in the chain, therefore the recommended best practice is to connect a maximum of 4 Charge Amps Aura 4G-LTE, or Charge Amps Aura with LAN connection, in series.

It is possible to daisy chain the network connection of several Charge Amps Aura 4G-LTE or Charge Amps Aura with LAN connection. For Charge Amps Aura 4G-LTE, use a separate router or an Aura 4G-LTE as an uplink. It is not possible to use one Charge Amps Aura with Wi-Fi as an uplink.

5 Installation

5.1 Mounting

N.B: Mounting shall only be performed by an qualified electrician.

1. Unpack Charge Amps Aura. Make sure that Charge Amps Aura is in a good condition and that all cables are properly seated. Do not place the face plate directly on to the ground.
2. Mark the mounting holes on the wall according to the dimensions in the drawing below*.

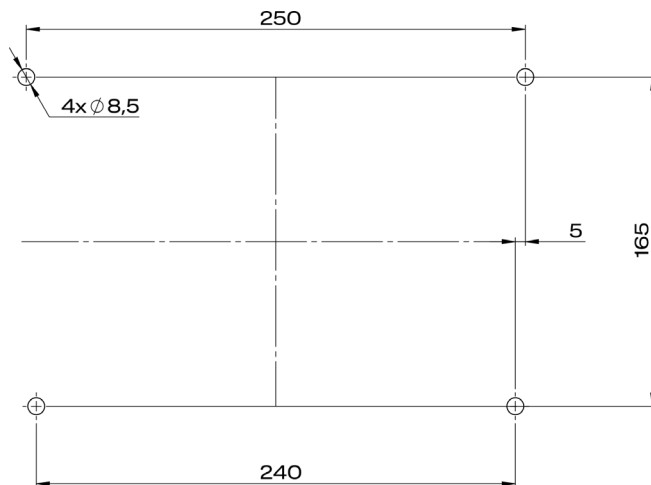

*Not to scale, [mm].

3. Unlock the cylinder lock. Rotate the front cover upwards and suspend the front.

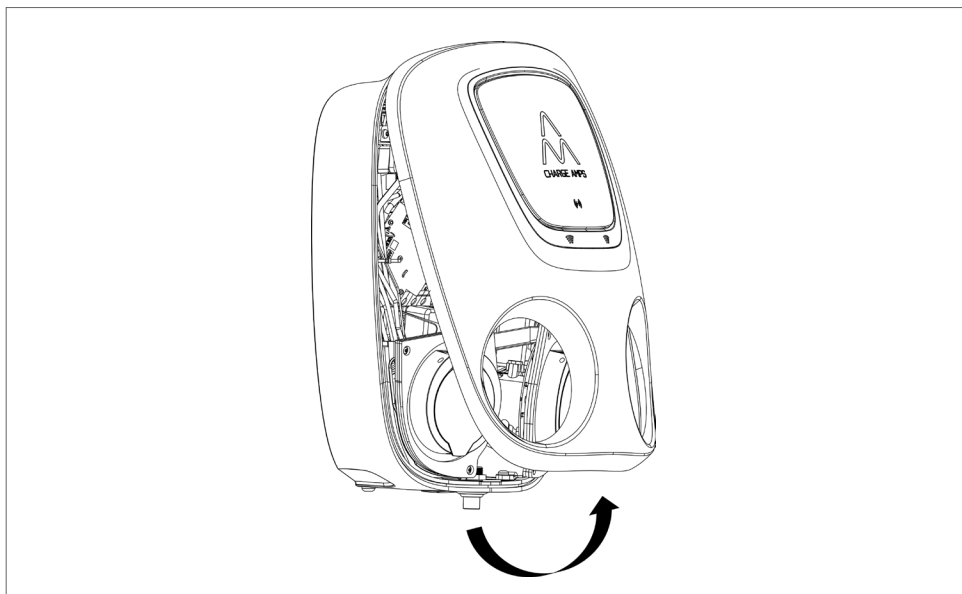

4. Remove the cable slide by unscrewing the two M6 screws.

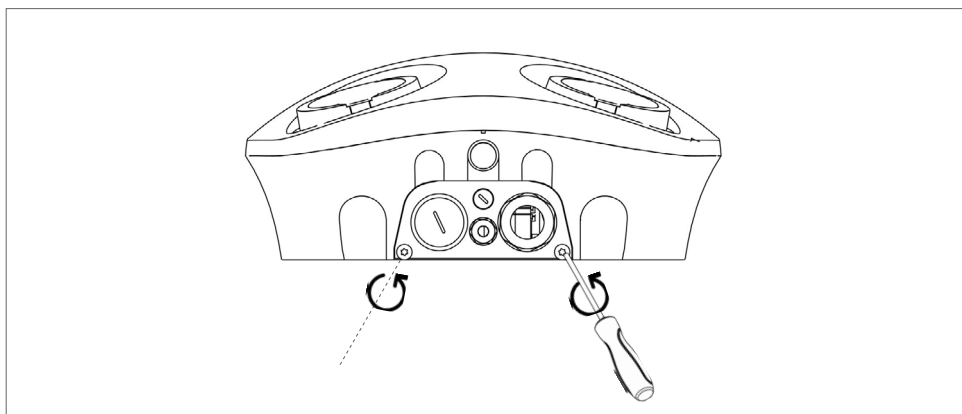

5. Attach the cable fittings for power and data (NOTE: cable fitting for data is only applicable for Charge Amps Aura with LAN connection).

N.B: Make sure to cover non-used cable entries with suitable plugs from the accessories.

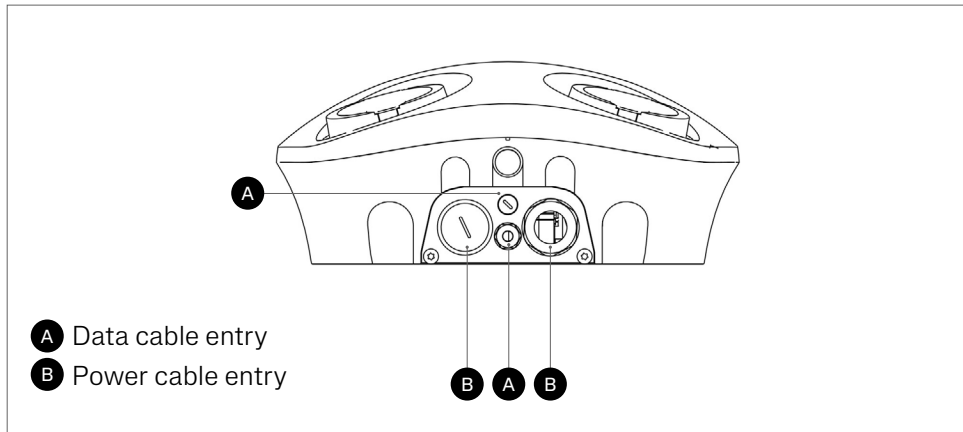

6. Reattach the cable slide to the back cover by securing the two M6 screws.

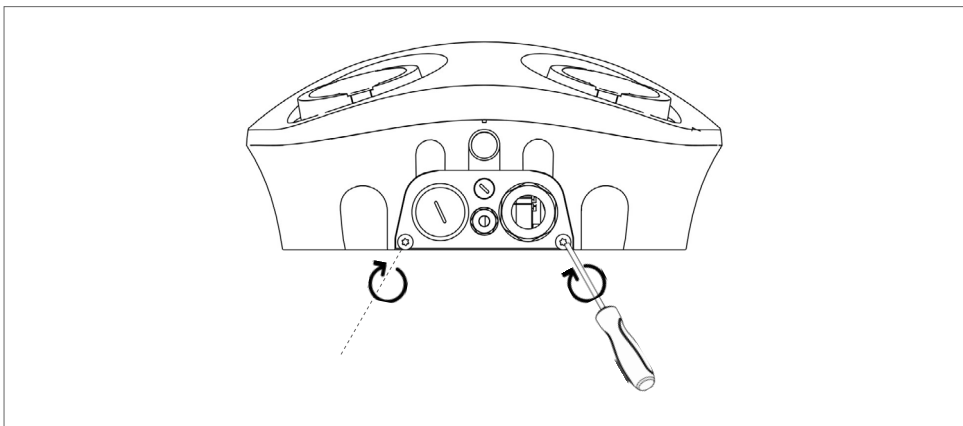

7. Align Charge Amps Aura to the wall and mount.

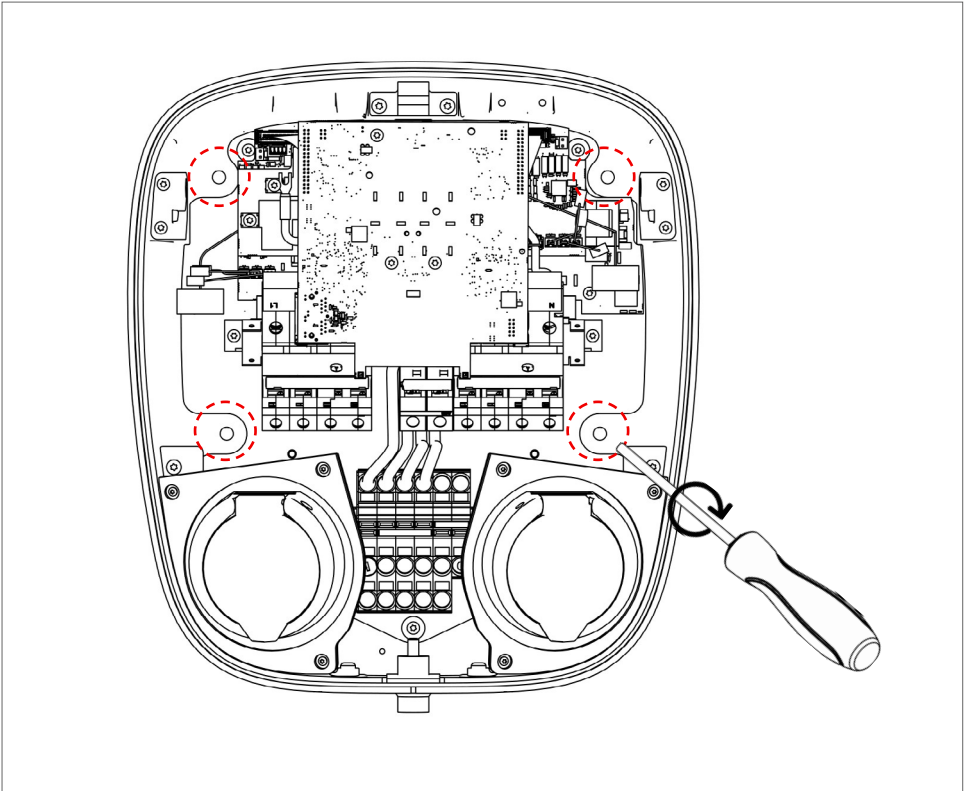

5.2 Connection

WARNING: Make sure that the power is turned off at the main switch and that the feed cable is isolated!

- Cable connection: L1, L2, L3, N, PE. The WAGO terminals are designed for a cable area of 2.5 to 16 mm².
- Make sure the incoming cabling is dimensioned to connect the Charge Amps Aura.

5.2.1 Cable connection

N.B: Only insert the power cable through the specific cable entry.

1. Pull the power cable through the cable entry.
2. Strip approximately 20 mm off the end of the conductors and follow the instructions for cable connection depending on your supply network:

3. For TN/TT network connection, connect the conductors to the terminal block:

TN/TT - single installation

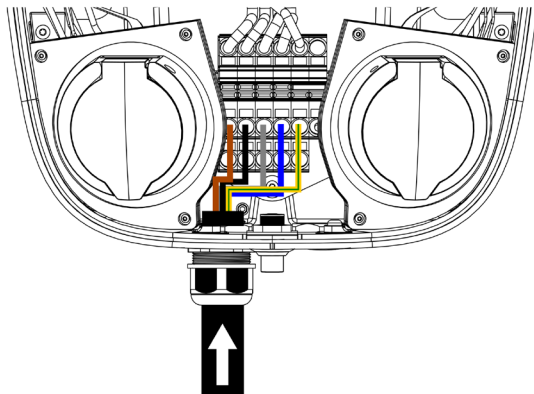

TN/TT - daisy chain installation

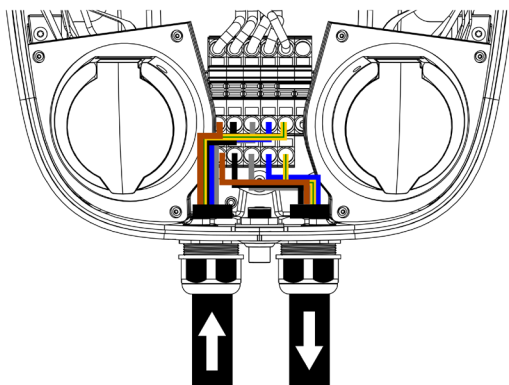

4. For IT network connection, connect the conductors to the terminal block using the provided Wago jumper (MPN: 2016-433). NOTE: The Wago jumper should be placed between L2 and N.

IT - single installation

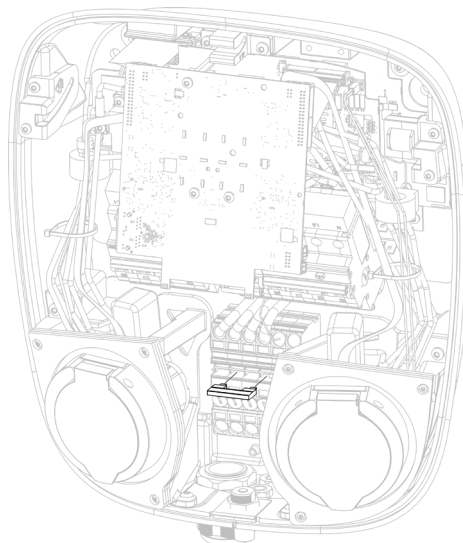
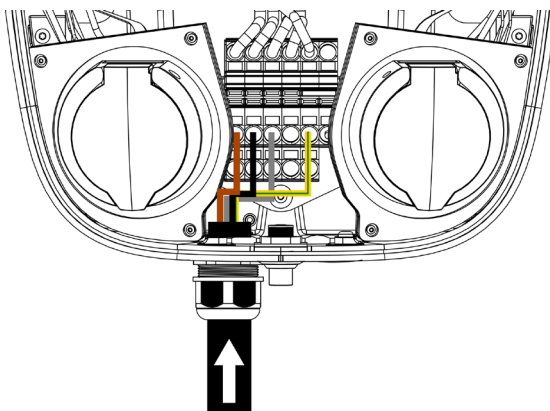

IT - daisy installation

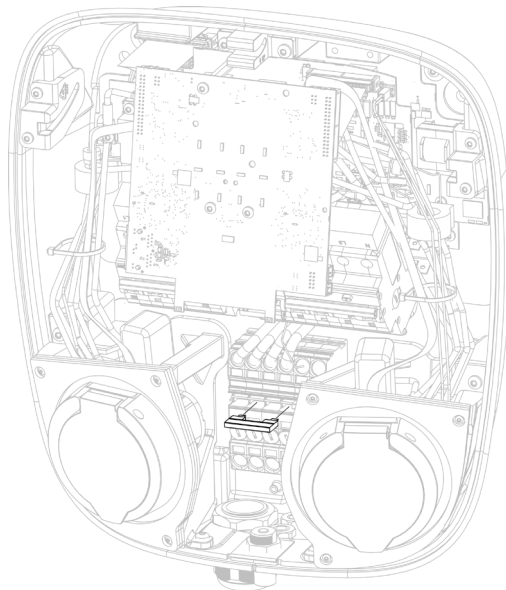
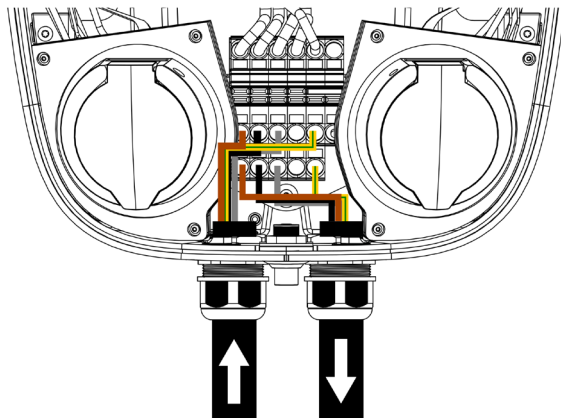

5. Once the cables are connected to the terminal block, minimize the risk of squeezing any cables by making sure no cables are sticking out above the red dotted line.

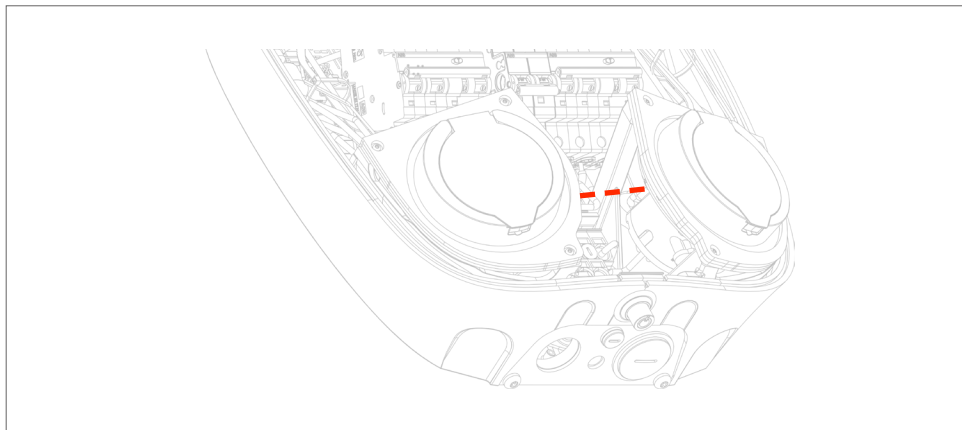

- For LAN connection: connect the Ethernet cable to the RJ45 port on the main card.

For 4G-LTE connection: insert the SIM card into the SIM card holder and make sure the modem is connected to the RJ45 port.

N.B: Only applicable if Charge Amps Aura shall be connected via LAN connection or 4G-LTE connection.

LAN connection

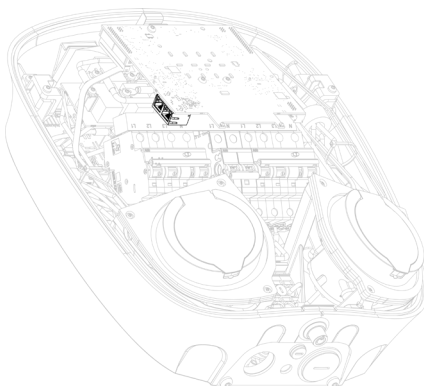

4G-LTE connection

4G-LTE modem

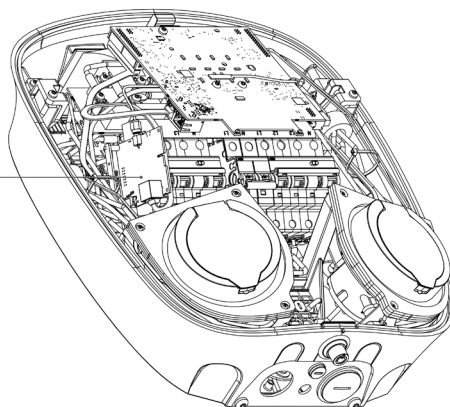

5.3 Reassemble

1. Once the cables are installed, make sure that the RCDs and the MCB are turned on.
2. Make sure that none of the internal cables that are highlighted below were disconnected during installation and make sure the connectors are fully inserted in their sockets.

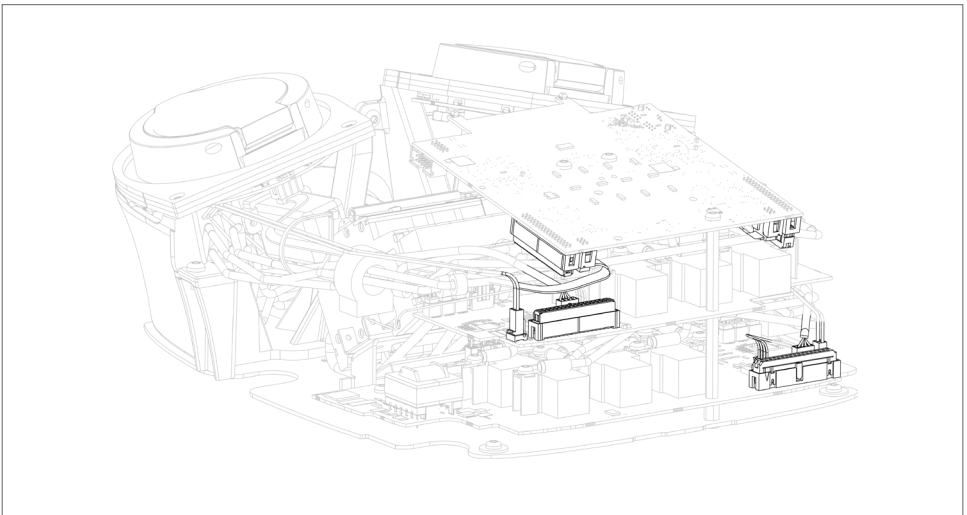

3. Close the front cover, making sure it does not interfere with any cables inside. Lock the front cover in place.
4. Turn the power on at the main switch.
5. A start-up sequence with self-tests is carried out.
6. Make sure that the ring lights around the sockets are green.

6 Configuration

N.B: Always register in Charge Amps Partner Portal to configure Charge Amps Aura.

Charge Amps Aura comes with two different communication protocols, OCPP 1.6J or CAPI. Follow the instructions for configuration based on the version of your Charge Amps Aura:

- Charge Amps Aura with product number 130908 and 130909 with communication protocol OCPP 1.6J: follow chapter 6.2.
- Charge Amps Aura with product number 101010 and 101010-LTE with communication protocol CAPI: follow chapter 6.3.

6.1 Create a Charge Amps Partner Account

Before starting the configuration, make sure to create an account in Charge Amps Partner Portal. Use your login credentials, or create a new account by following the steps below:

1. Create a User Account at Charge Amps Cloud
<https://my.charge.space/>
2. Visit our Help Center at:
www.chargeamps.com/support
3. Once you reached the Help Center, navigate to the inquiry form from the top menu and fill in the form.
4. You will receive an email with instructions for how to proceed and Charge Amps will notify you when your Partner Account has been created.

6.2 Connect Charge Amps Aura OCPP 1.6J version

N.B: Valid for Charge Amps Aura with product number 130908 and 130909.

There's three ways to connect Charge Amps Aura to the internet: via Charge Amps Aura Wi-Fi access point, via LAN or via 4G-LTE (only valid for Charge Amps Aura with product number 130908). Once connected to the internet, you can configure Charge Amps Aura in the local management interface.

Before starting the configuration process, make sure you have access to:

- The serial number for Charge Amps Aura (can be found in the documentation included in the packaging).
- The PIN code for Charge Amps Aura (can be found in the documentation included in the packaging).

N.B: Make sure to store and keep the PIN code safe for later use after installation!

6.2.1 Connect via Charge Amps Aura Wi-Fi access point

N.B: The Charge Amps Aura Wi-Fi access point is deactivated if the RJ45 port is actively connected.

Once the power is switched on, Charge Amps Aura will provide a Wi-Fi access point which is available for 10 minutes. Connect to the Charge Amps Aura Wi-Fi access point by using a smartphone, tablet or computer:

1. Set to airplane mode to avoid conflicting Wi-Fi.
2. Enter following information:
 - SSID: "AURA_nnnnnnA" (where "nnnnnn" equals the last 6 digits of the serial number).
 - Wi-Fi password: the PIN code for Charge Amps Aura.
3. Open a new page in a web browser and type in "192.168.250.1" in the address field to access the Local management interface.
4. In the Local management interface, sign in by entering the PIN code again.
5. Navigate to the Wi-Fi tab.
6. Connect Charge Amps Aura to the internet by entering the sign in details of the facility's Wi-Fi network and then save the settings.
7. Continue to chapter 6.2.4 and follow the instructions stated in the "Local management interface settings".

6.2.2 Connect via LAN

N.B: It is possible to daisy chain the LAN connection using the two RJ45 ports of Charge Amps Aura.

1. Make sure that Charge Amps Aura is connected to the local network via an ethernet cable one of the RJ45 ports.
2. Using a smart phone, tablet or computer, open a new window in the web browser.
3. Enter the IP address assigned to Charge Amps Aura in the address field to reach the Local management interface. (Log in to the router to find the IP address assigned to Charge Amps Aura).
4. In the Local management interface, sign in by entering the PIN code for Charge Amps Aura.
5. Continue to chapter 6.2.4 and follow the instructions stated in the "Local management interface settings".

6.2.3 Connect via 4G-LTE

N.B: Connection via 4G-LTE is only possible for Charge Amps Aura with product number 130908.

N.B: While connected to the 4G-LTE modem, it is not possible to reach the local management interface and configure Charge Amps Aura. To reach the local management interface, first use Charge Amps Aura Wi-Fi access point.

N.B: It is possible to daisy chain the 4G connection using the two RJ45 ports of Charge Amps Aura.

1. Make sure the unit is configured via the local management interface before connecting the 4G-LTE modem. This can be done by following the steps in chapter 7.1 "Connect via Charge Amps Aura Wi-Fi access point.
2. Insert the SIM card into the SIM card holder and make sure the modem is connected to the RJ45 port.
3. Charge Amps Aura will automatically connect to the internet once the power is on.
4. Verify the network connection by one of two following options:
 - Connecting a computer to the second RJ45 port of Charge Amps Aura and verify the internet connection over LAN, or
 - Connect a computer directly to the 4G-LTE modem and verify the internet connection over LAN.

6.2.4 Local management interface settings

In the local management interface, the electrical settings of the installation, how to handle RFID-tags for an offline-operated Charge Amps Aura and how to connect to a different cloud provider than Charge Amps Cloud can be configured.

Electrical installation settings

To configure the settings of the electrical installation, follow the steps below:

1. Select the Installation tab and fill in the different fields.
2. Save the settings.

RFID management for offline chargers

When Charge Amps Aura is connected to a cloud service, all management of RFID-tags is handled in the cloud. If Charge Amps Aura is to be operated offline, without a connection to a cloud service, management of RFID tags can be handled in the local management interface.

N.B: If Charge Amps Aura should be connected to a cloud service at a later stage, the tags added in the local management interface will be ignored.

To add and manage offline RFID-tags, follow the steps below:

1. Select the RFID tab and follow the instructions.
2. Save the settings.

Connect to a different cloud provider

If Charge Amps Aura is to be connected to a different cloud provider than Charge Amps Cloud, follow the steps below to set the correct cloud provider:

1. Navigate to the OCPP tab.
2. Enter the URL of the cloud provider which should be connected to Charge Amps Aura.
3. Save the settings wait 10 seconds for the settings to be saved, and then restart Charge Amps Aura.

6.3 Connect Charge Amps Aura CAPI version

N.B: Valid for Charge Amps Aura with product number 101010 and 101010-LTE.

There's three ways to connect Charge Amps Aura to the internet: via Charge Amps Aura Wi-Fi access point, via LAN or via 4G-LTE (only valid for Charge Amps Aura with product number 101010-LTE).

Before starting the connection process, make sure you have access to:

- The serial number for Charge Amps Aura (can be found in the documentation included in the packaging).
- The PIN code for Charge Amps Aura (can be found in the documentation included in the packaging).

N.B: Make sure to store and keep the PIN code safe for later use after installation!

6.3.1 Connect via Charge Amps Aura Wi-Fi access point

N.B: The Charge Amps Aura Wi-Fi access point is deactivated if one of the RJ45 ports is actively connected.

Once the power is switched on, Charge Amps Aura will provide a Wi-Fi access point which is available for 10 minutes. Connect to the Charge Amps Aura Wi-Fi access point by using a smartphone, tablet or computer:

1. Set to airplane mode to avoid conflicting Wi-Fi.
2. Enter following information:
 - SSID: "AURA_nnnnnnA" (where "nnnnnn" equals the last 6 digits of the serial number).
 - Wi-Fi password: the PIN code for Charge Amps Aura.
3. Open a new page in a web browser and type in "192.168.250.1" in the address field to access the Local management interface.
4. Connect Charge Amps Aura to the internet by entering the sign in details of the facility's Wi-Fi network in the bottom of the page.
5. Save the settings.

6.3.2 Connect via LAN

N.B: It is possible to daisy chain the LAN connection using the two RJ45 ports of Charge Amps Aura.

1. Connect the ethernet cable to one of the RJ45 ports.

6.3.3 Connect via 4G-LTE

N.B: Connection via 4G-LTE is only possible for Charge Amps Aura with product number 101010-LTE.

N.B: While connected to the 4G-LTE modem, it is not possible to reach the local management interface and configure Charge Amps Aura. To reach the local management interface, first use Charge Amps Aura Wi-Fi access point.

N.B: It is possible to daisy chain the 4G connection using the two RJ45 ports of Charge Amps Aura.

1. Insert the SIM card into the SIM card holder and make sure the modem is connected to one of the RJ45 ports.
2. Charge Amps Aura will automatically connect to the internet once the power is turned on.

7 Cloud connectivity

Charge Amps App and Charge Amps Cloud are available for Charge Amps Aura connected to Charge Amps as the cloud provider.

Charge Amps App

Please download Charge Amps App for full control, adjusting settings and enabling smart charging and scheduling.



Charge Amps Cloud

Please create an account in the Charge Amps Cloud to configure, control and manage your charger via our web interface.



My charge space →

<https://my.charge.space/>

Full product information

Visit www.chargeamps.com for Charge Amps Aura Installation Manual, Charge Amps Aura User Manual and other product documentation.



Product information →

<https://www.chargeamps.com/product/charge-amps-aura/>

8 Dismounting

N.B: Dismounting shall only be performed by an qualified electrician.

The power supply to the charger must be isolated before dismounting starts.

1. Perform a factory reset of Charge Amps Aura before powering it down. Contact the supplier before performing this action.
2. Turn the power off at the main switch.
3. Use this Installation Manual and follow the steps in reverse to dismount Charge Amps Aura in the correct order.

9 Maintenance

9.1 Regular maintenance

N.B: Never spray water or any other liquid directly on to the product.

- Visually check that the EV socket-outlet is free from damage.
- The outside of the product must be regularly wiped with a clean, dry cloth to remove dirt and dust.
- Do not use detergent to clean any of the product's components.

9.2 Preventative maintenance

N.B: Preventative maintenance should be performed by a qualified electrician once or twice each year to check that Charge Amps Aura is in good condition.

- Remove the front cover and make a visual check of the cable connections.
- Gently rock the internal RCBO to make sure it's properly seated.

10 Product support and service

If you have any questions or problems with the product, support is always available. To find answers to your questions most quickly: Read through the Installation Manual or User Manual to check whether your questions are answered there.

If your question is not answered, please:

1. Contact your supplier or cloud provider.
2. If you need service or repair, start by contacting the supplier from whom you purchased the product.
3. For additional information, visit our Help Center at: www.chargeamps.com/support..

11 Warranty

Warranty terms may differ from market to market. Contact your supplier regarding the warranty terms.

www.chargeamps.com

Charge Amps AB (publ)
Frösundaleden 2B, 8th floor
SE-169 75 Solna, Sweden

Charge Amps UK Ltd
4th Floor, 3 More London Riverside
London SE1 2AQ, United Kingdom