

Charge Amps Luna



Installation Manual

English

Table of content

1	Safety	5
2	Technical data	6
3	Product overview	9
3.1	Package Contents	10
4	Before Installation	12
4.1	Recommended tools	12
4.2	Materials provided by installer	12
4.3	Mounting requirements	13
4.4	Electrical requirements	14
4.4.1	Short circuit safety – external MCB	14
4.4.2	Residual current safety	14
4.5	Internet access	15
4.5.1	Wi-Fi 2,4 GHz connection	15
4.5.2	LTE Cat 1bis connection	16
5	Installation	17
5.1	Mounting	17
5.2	Connection	18
5.2.1	Cable connection	18
5.3	Reassemble	24
6	Configuration	25
6.1	Create a Charge Amps Partner Account	25
6.2	Configure via Charge Amps Installer App	26
6.3	Configure via Installation Wizard	26

7	Cloud connectivity	27
8	Dismounting	28
9	Maintenance	29
10	Product support and service	29
11	Warranty	30



Respect the environment! Must not be discarded with household waste! This product contains electrical or electronic components that should be recycled. Leave the product for recycling at a designated location e.g. the local authority's recycling station.

Disposal of the product must comply with the local environmental laws and guidelines. The product consists of recyclable plastics and electronics, and should be recycled as specified for these materials.



In conformity with the relevant EU directives.

Neglecting to follow and carry out the directions, instructions and safety precautions in this Installation Manual implies that any warranty provisions will be cancelled and that Charge Amps AB can reject any and all claims for compensation in connection with any injuries/damage or incidents – direct or indirect – that are a result of such negligence.

Charge Amps AB does not give any warranties as to the accuracy or completeness of this document and shall have no liability for the consequences of using such information. Charge Amps AB reserves the right to make changes to information published in this document without notice. Visit www.chargeamps.com for the latest document releases.

© Copyright Charge Amps AB. All rights reserved. Copying, amending and translating are strictly forbidden without prior written approval from Charge Amps AB.

1 Safety

WARNING: Read all instructions before installation!

- The product must only be installed by a qualified electrician in accordance with the Installation Manual.
- Make sure to switch the power off at the main switch before installation or service.
- For this product, automatic reclosing of protective devices is not allowed.
- Improper use and negligence to follow the instructions of this Installation Manual may create a risk of personal injury.
- National installation requirements and restrictions apply.
- Only use this product for charging compatible electric vehicles.
- Inspect the product for visible damage before use.
- Never attempt to repair or use the product if it is damaged.
- Make sure that the product is in good condition and that all cables are properly seated before use.
- Do not immerse the product in water, subject it to physical abuse or insert foreign objects in any part of the product.
- Never attempt to disassemble the product in any way other than what is described in the Installation Manual.
- Make sure no flammable, explosive, corrosive or combustible materials, chemicals, or fumes are nearby the mounting position.

2 Technical data

Charging mode	Mode 3
EV power supply identifier	
Metering	1 to 3 phase voltage, current and power
Socket	Type 2, 22 kW ⁽¹⁾
Rated voltage (U _n)	230/400 V
Rated insulation voltage (U _i)	250/400 V
Rated impulse withstand voltage (U _{imp})	4 kV
Rated frequency (f _n)	50 Hz
Rated current (I _n)	32 A
Rated conditional short-circuit current (I _{cc})	1,5 kA (measured at charger input terminals)
Rated diversity factor (RDF)	1 (can be lowered if used together with a load balancing functionality)
Residual current safety	Built in RCD type B complying with IEC 60947-2. AC: 30mA, DC: 6mA
Short circuit safety	External MCB is required ⁽²⁾
Protection against electrical shock	Class I
Types of earthing system	TN/TT/IT
Overvoltage category	III
Pollution degree	3
Electromagnetic compatibility	Environment B
Operating temperature	-35°C to +45°C

Altitude	0 m to 2000 m
IP code	IP54
IK code	IK10
Mechanical resistance	High
Dimensions (W x D x H)	210 x 80 x 220 mm
Weight	1,3 kg
Characteristics of power supply and output	AC EV supply equipment connected to AC supply network, permanently connected
External design and method of mounting	Enclosed wall-mounted surface type: - Surface mounted on walls - Stationary ground and floor mounted installation with accessory Next Green Poleplate for Charge Amps Luna.
Type of construction	Fixed parts
Intended use and location type	By ordinary persons, indoor and outdoor installation with nonrestricted access
Incoming power cable, outer dimensions	Ø9 – 18,5 mm
Incoming power cable, conductor dimensions	Cu, up to 6 mm ²
RFID	Type: ISO/IEC 14443 Typ A 13.56 MHz Mifare Range: 13.553 – 13.567 MHz Max output: 24 dBm

Bluetooth	Version: Bluetooth 5.0 (LE) and Bluetooth LE 5.3 certified Range: 2400 – 2480 MHz Max output: 19 dBm
Wi-Fi	Type: 802.11 b/g/n/ax Range: 2412 – 2484 MHz Max output: 20.5/20.0/19.0/19.0 dBm@802.11b/g/n/ax
Cellular networks communication	Type: LTE-FDD and GSM Supported bands: B3/B7/B8/B20/B28 Range: 703–915/1710–1785/2500–2570 MHz Max output: 25 dBm @LTE-FDD, 35 dBm @GSM. SIM-card: built-in
Communication protocol	OCPP 1.6J ISO 15118 hardware ready

⁽¹⁾The charging power is subject to external conditions, such as outside temperature, car battery state of charge, or if there's a load balancing function or charging schedule applied.

⁽²⁾See chapter 4.4.1

3 Product overview

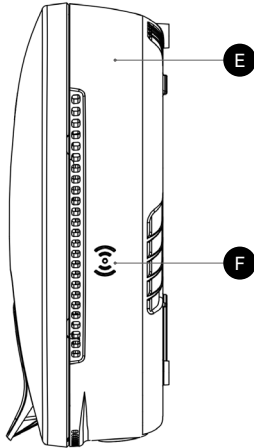
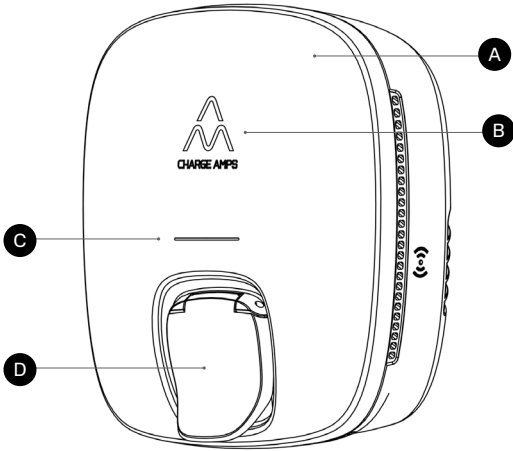

- A** Front cover
- B** Illuminated logotype
- C** Status LED
- D** EV socket-outlet
- E** Charging unit
- F** RFID reader

3.1 Package Contents

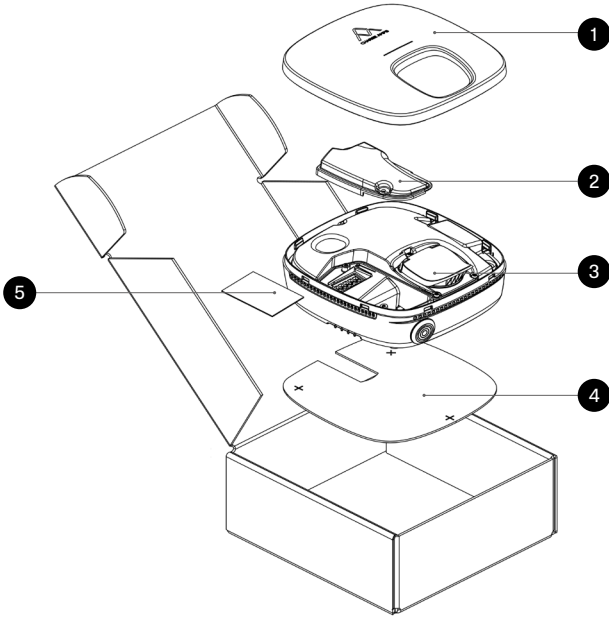

5



RFID tag

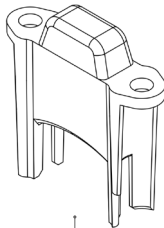

Strain relief



2x long screw



2x short screw

- 1 Front cover
- 2 Installation lid
- 3 Charging unit
- 4 Drill template
- 5 Accessories bag:
 - 1x RFID tag
 - 1x Strain relief
 - 2x long screw (PT40x30)
 - 2x short screw (PT40x14)

Additional contents:

- Quick Guide
- Welcome letter

4 Before Installation

Before starting the installation process, make sure you have a Partner Account in Charge Amps Cloud to be able to configure Charge Amps Luna, and that you have downloaded Charge Amps Installer App. See chapter 6.1 for instructions on how to create a Partner Account and how to download the Installer App.

4.1 Recommended tools

- Screwdriver T20
- Drill
- Multimeter
- Laser/spirit level
- Wire stripper for cabling
- Mobile phone, tablet or computer
- Wi-Fi analyzer app to ensure sufficient Wi-Fi strength at the installation location
- Access to an EV simulator, an EV charging station tester or an electric vehicle for final testing of the installation.

4.2 Materials provided by installer

- 3x Stainless mounting screws (5x40mm or longer, non-countersunk screws) for fastening Charge Amps Luna to the wall. Long bit is required.
- Installation cable, according to the charging capability of the product.

4.3 Mounting requirements

- If possible, do not mount the Charge Amps Luna in direct sunlight. Overheating may impact the charging power.
- Make sure the wall can support a weight of 1,3 kg and the tractive force from the inserted cabling.
- Do not install Charge Amps Luna in confined spaces.
- Use screws and plugs (if required) suitable for the wall material.
- Charge Amps Luna must be mounted upright.
- Minimum mounting height: 900 mm, measured from the ground to the bottom of Charge Amps Luna.

4.4 Electrical requirements

4.4.1 Short circuit safety – external MCB

N.B: Local regulations for the electrical installation should always be followed!

An MCB with the following specifications is required:

- Up to 32 A MCB, curve B, with Energy Limiting Class 3.
- Let-through energy at 1.5 kA prospective short-circuit current: 4.75 kA²s
- Cut-off current: 1.95 kA
- Compliant with IEC 60947-2, IEC 60947-6-2, or IEC 61009-1. Or compliant with the relevant parts of the IEC 60898 or IEC 60269 series.

4.4.2 Residual current safety

N.B: Local regulations for the electrical installation should always be followed!

Charge Amps Luna has a built-in RCD Type-B complying with IEC 60947-2. AC: 30mA, DC: 6mA.

Instructions for how to test and reset the built-in RCD can be found in Charge Amps Luna User Manual.

For some markets, an upstream RCD is required in the electrical installation. If an upstream RCD is required, it is recommended to be selected as follows:

- If selectivity in relation to the built-in RCD in Charge Amps Luna is required: RCD Type A Type S, 100mA or 300mA.
- If selectivity in relation to the built-in RCD in Charge Amps Luna is not required: RCD Type A, 30mA.

4.5 Internet access

N.B: Wi-Fi is recommended for optimal performance.

Both Wi-Fi and LTE connection are available for Charge Amps Luna. If a Wi-Fi connection is configured, it will be prioritized over LTE.

4.5.1 Wi-Fi 2,4 GHz connection

Wi-Fi connection is recommended, and the placement of Charge Amps Luna is key to solid Wi-Fi connectivity. Before installing Charge Amps Luna:

1. Use a Wi-Fi analyzer app to measure the Receive Signal Strength Indicator (RSSI). Sufficient network signal strength should be better than -65 dBm.
2. If you can't find a good connection, you might need to use a Wi-Fi extender, move the router or Charge Amps Luna to a better location.

For more information about Wi-Fi connection, please visit our Help Center at: www.chargeamps.com/support

4.5.2 LTE Cat 1bis connection

N.B: Note that the LTE connection is a paid service. For more information see www.chargeamps.com/product/4g-connectivity/

The first time the Charge Amps Luna attach to the network it will require some additional time (up to ten minutes).

Please be aware that mobile operator networks may change and interference and noise disturbance might be added over time. Small differences in location and environment might impact the signal strength.

5 Installation

5.1 Mounting

1. Unpack Charge Amps Luna and make sure it is in good condition.
2. Make sure the mounting surface is flat and use the drill template to mark the mounting holes on the wall.
3. Mount the Charging unit to the wall.

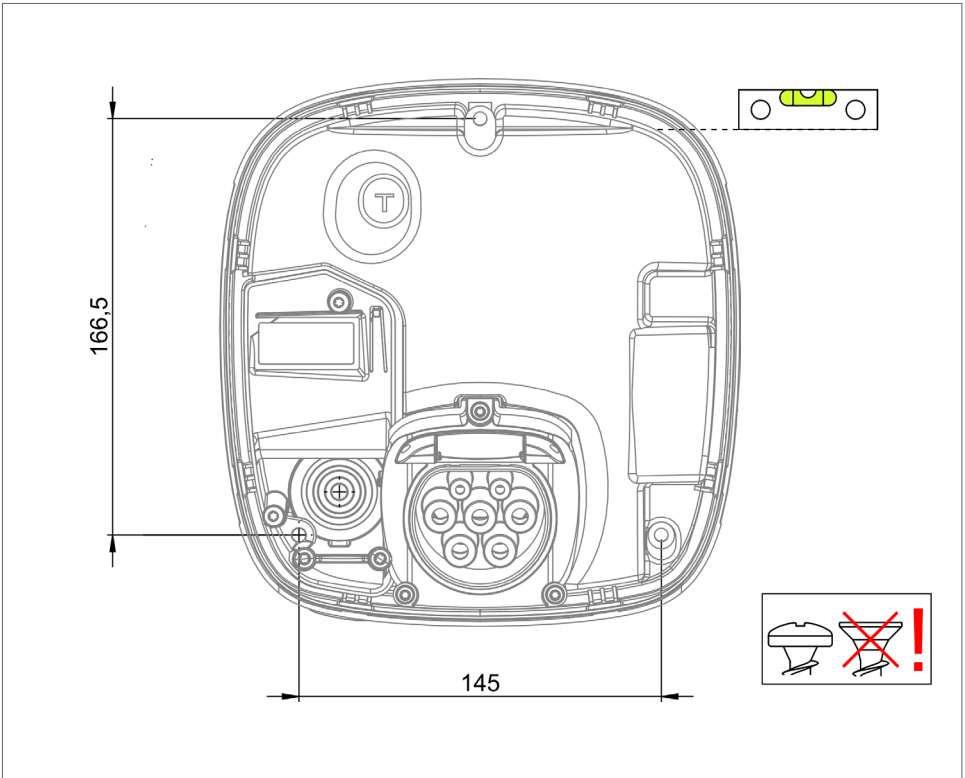

5.2 Connection

WARNING! Make sure the power is turned off at the main switch and that the feed cable is isolated!

5.2.1 Cable connection

N.B: Only insert the cables through the specified cable entries.

There are two options for cable entry: via the back or bottom of Charge Amps Luna.

1. For back side cable entry, make a hole in the rubber grommet and pull the cable through the back of Charge Amps Luna.

Back side cable entry

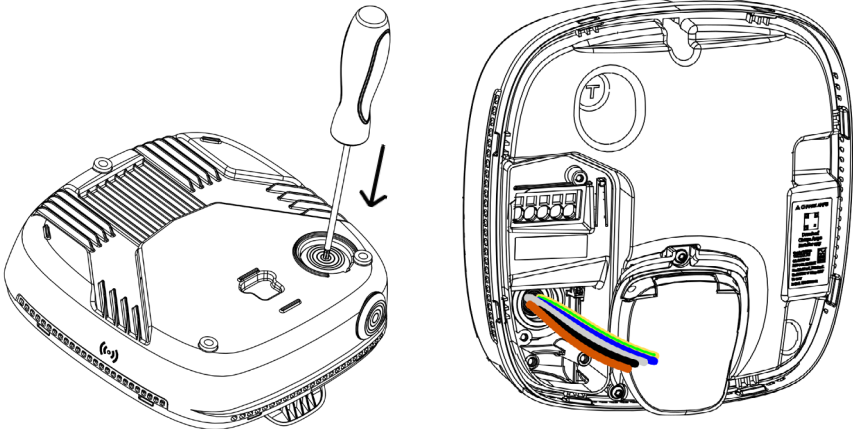

2. For bottom side cable entry, make a hole in the rubber grommet, pull the cable through the cable entry and screw the strain relief in place (Max. 1 Nm).

Bottom side cable entry

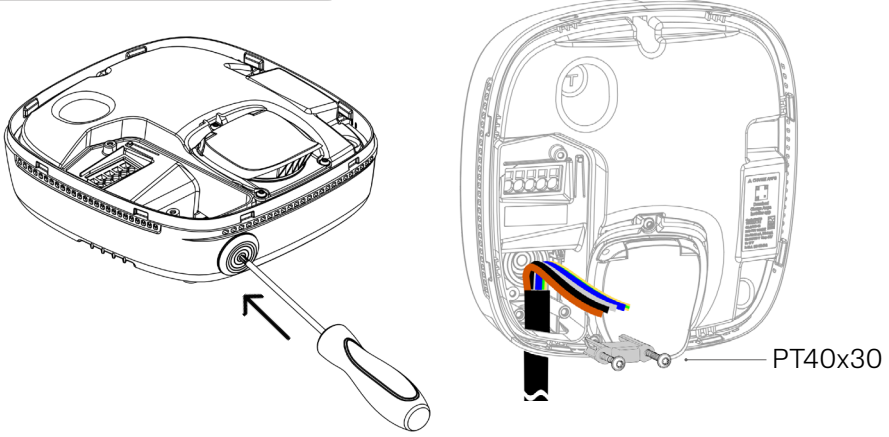

3. Strip the cables.

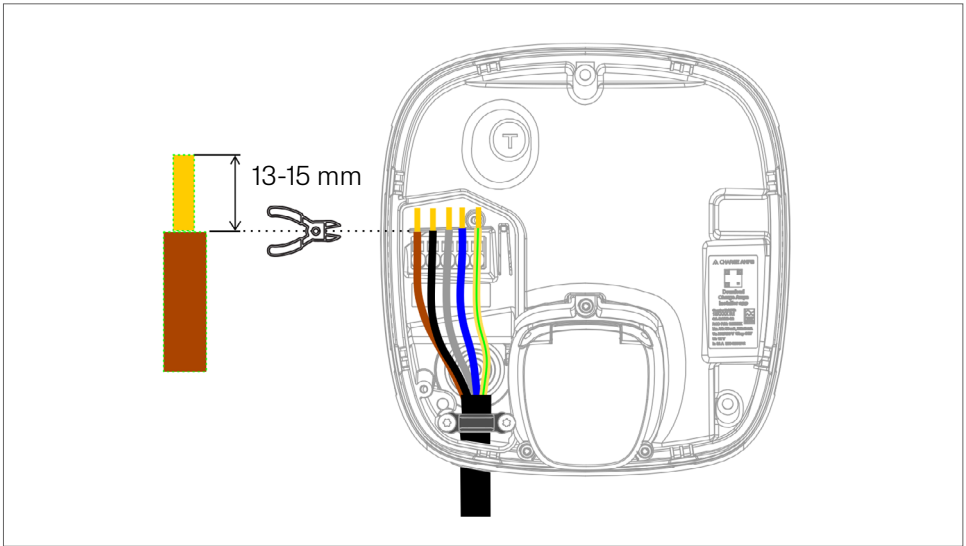

4. Depending on the type of installation and network connection, connect the cables according to the wiring diagram on the next page:

N.B: Compared to other Charge Amps chargers, Charge Amps Luna can not internally rotate the connected phases after the physical installation is completed. Hence, take additional care when selecting which phase to install on the L1 connector on Charge Amps Luna.

N.B: If the installation site contains more than one Charge Amps Luna, it is strongly suggested to rotate the installation phase cables for each installed Charge Amps Luna, to spread the load across the phases of the installation site.

TN/TT

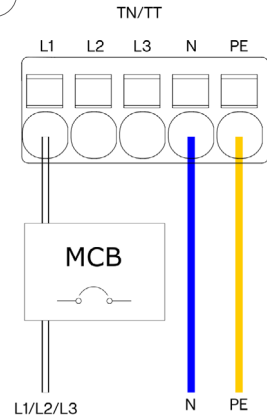

1 phase connection

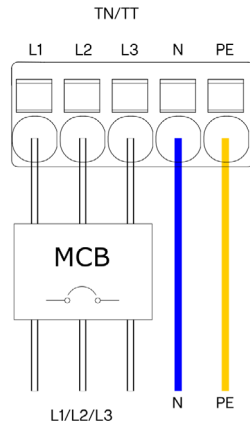

3 phase connection

IT

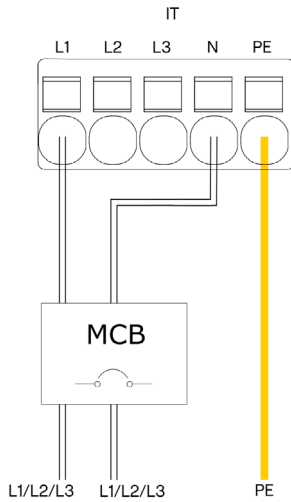

1 phase connection

5. Connect the cables.

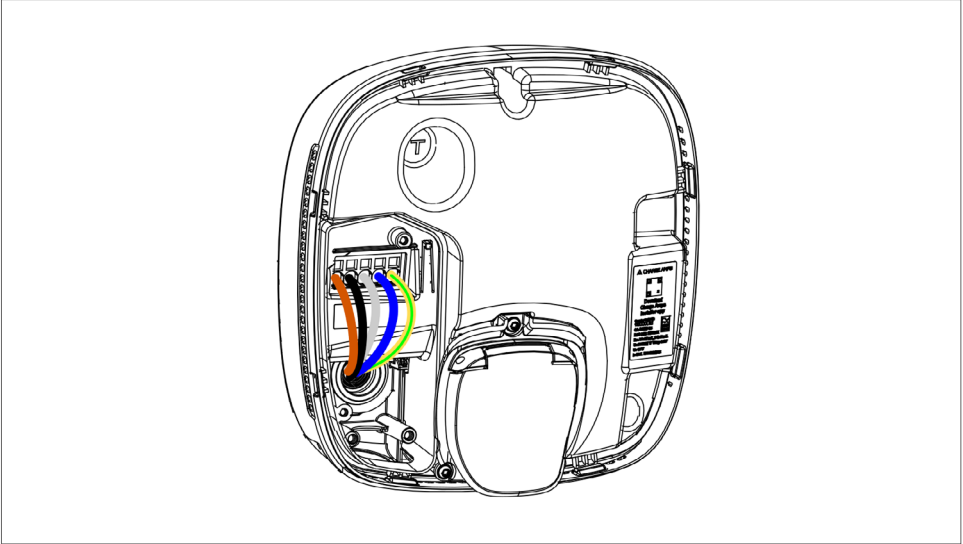

6. Mount the installation lid and screw it in place (Max. 2 Nm).

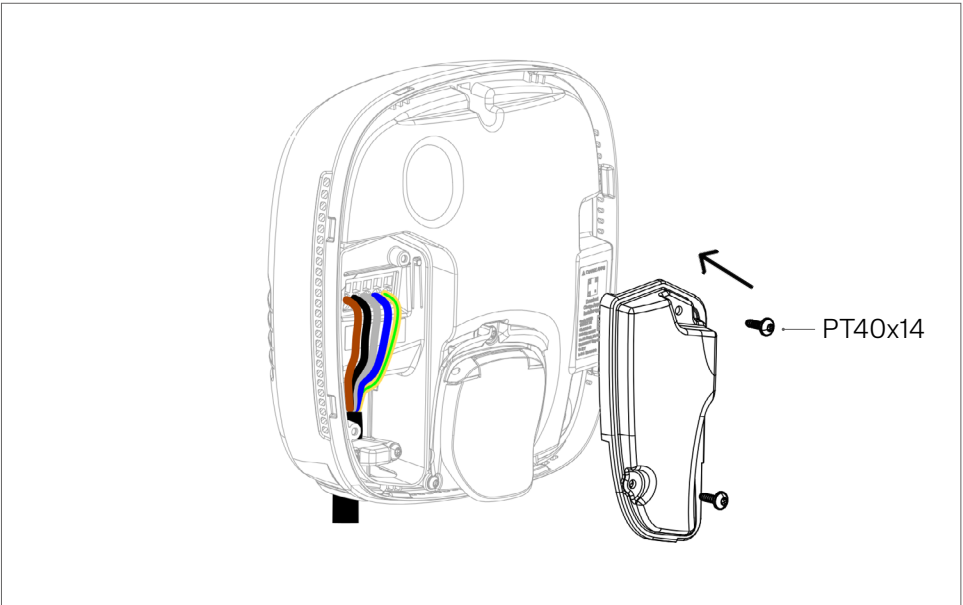

7. Turn on the power at the main switch.
8. Make sure the Status LED and Illumination logo are on.
9. Test the internal RCD according to the instructions in the Charge Amps Luna User Manual.
10. Once the test of the RCD is completed, continue chapter 5.3 to reassemble Charge Amps Luna.

5.3 Reassemble

1. Carefully press the Front cover in place.

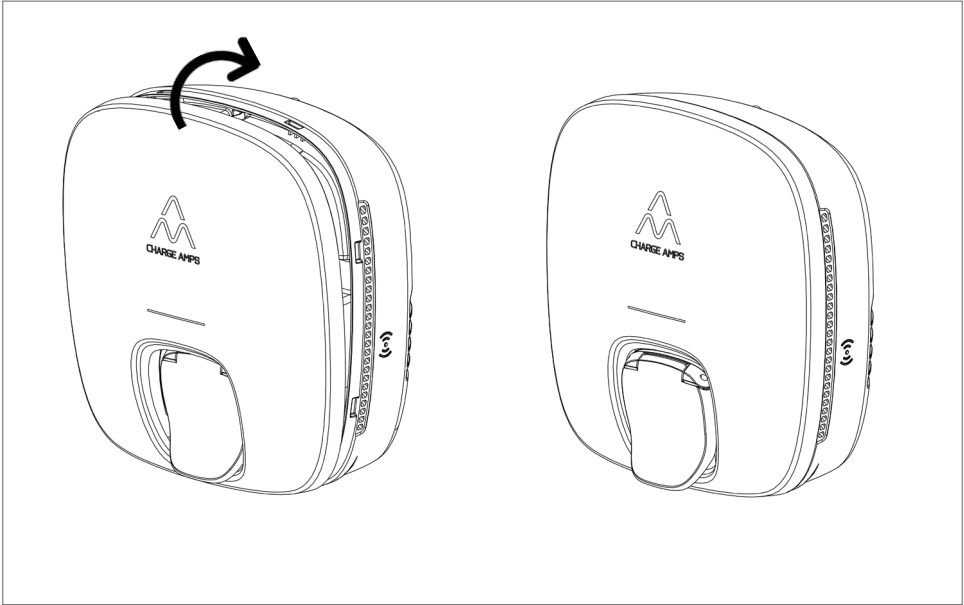

6 Configuration

N.B: Always register in Charge Amps Partner Portal to configure Charge Amps Luna.

There's two ways to configure Charge Amps Luna, via the Charge Amps Installer App or via the Installation Wizard in Charge Amps Cloud. Before starting the configuration, make sure to create a Partner Account in Charge Amps Partner Portal.

6.1 Create a Charge Amps Partner Account

Use your login credentials or create a new account.

1. Click on the link below and navigate to the top right corner of the webpage to set your language preference:

<https://my.charge.space/partner/#/login>

2. Once you've set the language, close the window and click on the following link to fill out the form and to apply for a Partner Account:

<https://my.charge.space/partner/#/registerPartner>

3. You will receive a confirmation email of your registration and with instructions on how to proceed.

6.2 Configure via Charge Amps Installer App

The Bluetooth interface is available 20 minutes after boot-up. If no connection is established within 20 minutes, a restart of Charge Amps Luna is required to re-activate the Bluetooth interface.

1. Open the app and press the button for configuration on the front page
2. Select the Charge Amps Luna you wish to configure and enter the PIN code. (The PIN code can be found in the Welcome letter included in the box of Charge Amps Luna).
3. Follow the instructions given in the Installer App to enter details about the installation and to configure the connectivity for Charge Amps Luna.

N.B: To configure Load balancing and other functionality, go to Charge Amps Partner Portal

6.3 Configure via Installation Wizard

To use the Installation Wizard in Charge Amps Cloud, Charge Amps Luna must be connected to the internet and Charge Amps Cloud. By default, Charge Amps Luna will use LTE Cat 1bis to connect to the mobile network and automatically connect to Charge Amps Cloud.

1. Login to Charge Amps Partner Portal, start the Installation Wizard and follow the steps in the Installation Wizard:
<https://my.charge.space/partner>

If any question is not answered in this Installation manual, please contact the supplier, see www.chargeamps.com/support.

7 Cloud connectivity

Charge Amps Installer App and Charge Amps Cloud are available for Charge Amps Luna connected to Charge Amps as the cloud provider.

Charge Amps Installer App

Please download Charge Amps Installer App, available in App store and Google Play.



Charge Amps Cloud

Please create an account in the Charge Amps Cloud to configure, control and manage your charger via our web interface.



My charge space →

<https://my.charge.space/partner/>

Full product information

Visit www.chargeamps.com for Charge Amps Luna Installation Manual, Charge Amps Luna User Manual and other product documentation.



Full product information

<https://www.chargeamps.com/product/charge-amps-luna>

8 Dismounting

The power supply to the charger must be isolated before dismounting starts.

1. Turn the power off at the main switch.
2. Using a flat screwdriver, carefully bend the front cover open.

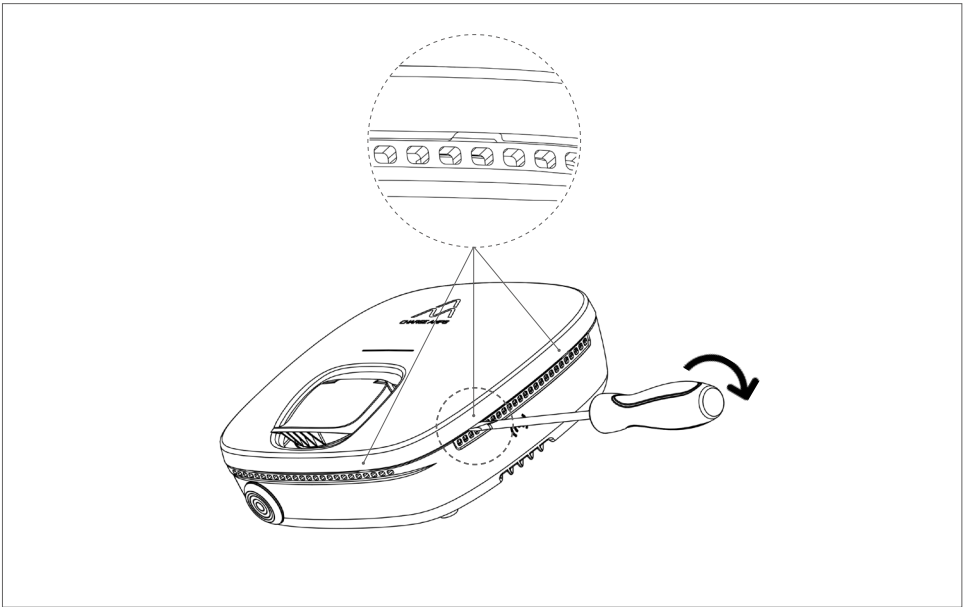

3. Use this Installation manual and follow the steps in reverse order to dismount Charge Amps Luna in the correct order.

N.B: Dismounting shall only be performed by a qualified electrician.

9 Maintenance

WARNING: Never spray water or any other liquid directly on the product.

- Visually check that the EV socket-outlet is free from damage.
- The outside of the product must be regularly wiped with a clean, dry cloth to remove dirt and dust.
- Do not use detergent to clean any of the product's components.

10 Product support and service

If you have any questions or problems with the product, support is always available. To find answers to your questions most quickly: Read through the Installation Manual or User Manual to check whether your questions are answered there.

If your question is not answered, please:

1. Contact your supplier or cloud provider.
2. If you need service or repair, start by contacting the supplier from whom you purchased the product.
3. For additional information, visit our Help Center at: www.chargeamps.com/support.

11 Warranty

Warranty terms may differ from market to market. Contact your supplier regarding the warranty terms.

www.chargeamps.com

Charge Amps AB (publ)
Frösundaleden 2B, 8th floor
SE-169 75 Solna, Sweden